

Single-wire CAN transceiver AU5790

The most cost-effective way to talk to your car

NXP's family of single-wire controller area network (SW-CAN) transceivers is designed for use in cost-sensitive vehicle body networking applications. Compared with current alternative systems, the AU5790 reduces wiring, assembly and maintenance costs for automotive manufacturers.

Key features

- ▶ Supports in-vehicle class B multiplexing via single bus line with ground return
- ▶ 41.6 kbits/s CAN bus speed with loading as per J2411
- ▶ Up to 100 kbits/s high-speed transmission mode
- ▶ Low RFI due to output wave shaping
- ▶ Direct battery operation with protection against load dump, jump start and transients
- ▶ Bus terminal protected against short-circuits and voltage transients
- ▶ Thermal overload and loss of ground protections
- ▶ Supports communication between control units even when network in low-power state
- ▶ Advanced sleep/wake-up functionality
- ▶ 70 μ A typical power consumption in sleep mode
- ▶ 8- and 14-pin small outline packages
- ▶ ± 8 kV ESD protection on bus and battery pins
- ▶ Low number of external components

Key applications

- ▶ Body electronics
- ▶ Comfort systems

Benefiting from features such as high-speed mode, embedded protections and advanced functionality to minimize power consumption, the AU5790 SW-CAN device delivers top-class performance. Primarily intended for in-vehicle multiplex and dedicated network applications, it provides an interface between the CAN data link controller and a single wire physical bus line in a range of applications, such as climate control, door locks, instruments clusters, seat positioning and other body and convenience systems.

The AU5790 provides advanced sleep/wake-up functions, minimizing power consumption and reducing battery load when a vehicle is parked, allowing enhanced battery life during ignition-off operation. In addition, the unique high-voltage wake-up feature allows normal bus communications without disturbing any sleeping nodes. A bus speed of up to 33.3 kbits/s can be achieved on a network with 32 full bus nodes, although higher speeds are possible with modified bus loading. Fast transfer of larger blocks of data is supported using the 83 kbits/s high-speed data transmission mode.

Adding to NXP's extensive automotive product portfolio, the AU5790 product family offers automotive manufacturers a fourfold increase in performance compared with single-wire non-CAN body systems. In addition, our new family of CAN transceivers features built-in fault tolerance for protection against loss of system ground and communications disruptions during these events. The new transceiver family includes robustness against electrostatic discharge by featuring 8 kV ESD capability on the battery and CanH pins and has built-in surge protection, ensuring full compliance with SAEJ113 / ISO 7637-1 specifications.

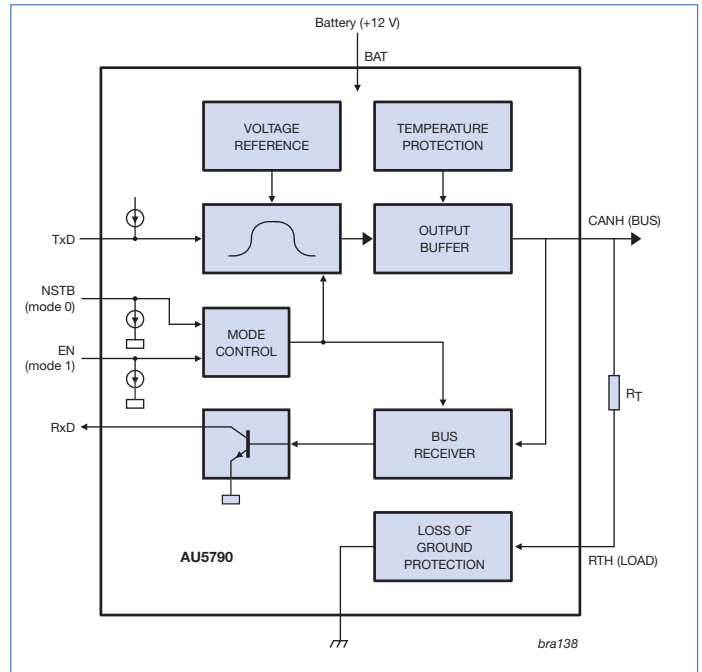

AU5790 block diagram

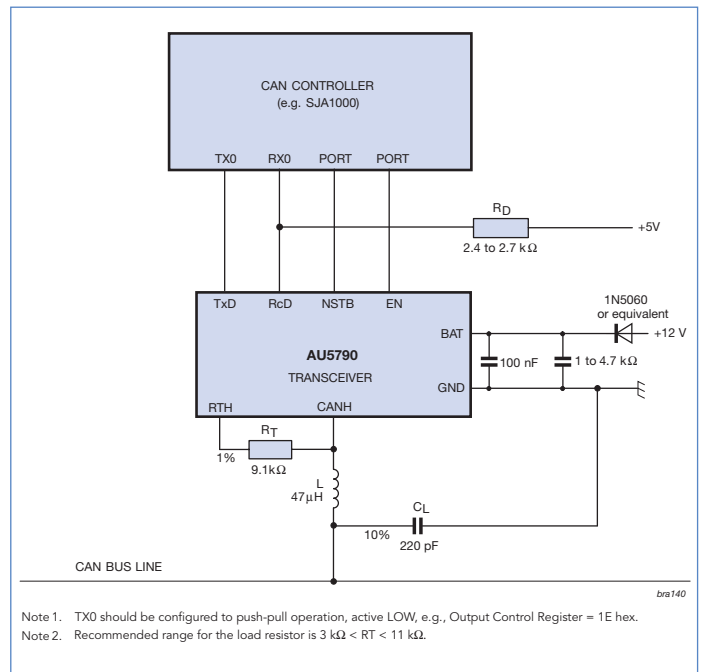

Application circuit example for the AU5790