



## NXP system basis chip family UJA107xA

# Latest SBCs make automotive networked ECUs more flexible, more scalable

These second-generation CAN/LIN System Basis Chips (SBCs) optimize performance, power consumption, and cost in electronic control units (ECUs) for a broad range of automotive applications.

### Key features

- ▶ ISO11898-2 and ISO11898-5 compliant HS-CAN transceiver
- ▶ LIN2.1, LIN2.0 and J2602 compliant LIN transceiver
- ▶ Scalable voltage regulator (3.3 or 5 V)
- ▶ Separate voltage regulator for CAN transceiver
- ▶ 2 wake-up inputs with cyclic biasing option
- ▶ Very low Standby mode current: 75  $\mu$ A (typ) with V1 active
- ▶ Very low Sleep mode current: 55  $\mu$ A (typ)
- ▶ Full wake-up capability in Standby and Sleep mode
- ▶ Operation down to 4.5 V BAT  $\geq$ 4b pulse (cranking) robustness
- ▶ Excellent ESD protection:  $\pm$ 8 kV HBM,  $\pm$ 6 kV IEC 61000-4-2
- ▶ Excellent EMC performance for robust, interference-free operation in the car
- ▶ Integrated failsafe functions: Watchdog, Limp Home, Global Enable
- ▶ Compact Dark Green HTSSOP32 package (6.1 x 11 mm)

### Key applications

- ▶ Body control modules
- ▶ Climate control
- ▶ Seat control
- ▶ Electric power steering (EPS)
- ▶ Adaptive lighting
- ▶ Rain/light sensors
- ▶ Parking assistance
- ▶ Transmission control

NXP's UJA107xA SBCs vastly simplify ECU design and layout, reducing required board space, and improving quality and reliability, while significantly reducing the overall ECU cost.

Today's new cars have over 50 ECUs on board, so it's imperative for OEMs to select components that are compact, cost-efficient, and reliable over the long term. The robust, highly flexible UJA107xA family meets these requirements, helping OEMs bring advanced safety and comfort features to vehicles in all segments of the worldwide automotive market.

The UJA107xA family offers a very high level of integration, performance, and scalability. Each device integrates industry-leading CAN and LIN transceivers along with a scalable voltage regulator for the on-board microcontroller and peripherals.

In addition, the UJA107xA family features SPI microcontroller interfacing and an integrated watchdog. Two independent wake ports enable the ECU to wake out of low power mode.



The devices offer a high level of ESD protection and excellent EMC performance. Also, with extremely low standby and quiescent currents, the devices help reduce fuel consumption and thus contribute to the reduction of CO<sub>2</sub> emissions.

The scalable voltage regulator is unique to NXP. The LDO can optionally be extended with a PNP transistor to increase the current capability up to 250 mA. The implementation allows the use of a wide range of PNP transistors and also enables the placement of the PNP transistor away from the SBC. This enables an ECU design with a significantly improved thermal behavior.

The entire family is pin-to-pin compatible and uses the same compact Dark Green HTSSOP32 package. All UJA107xA SBCs can be offered with a 3.3 or 5 V power supply, and with or without a watchdog, for optimal fit.

### UJA1078A Block diagram

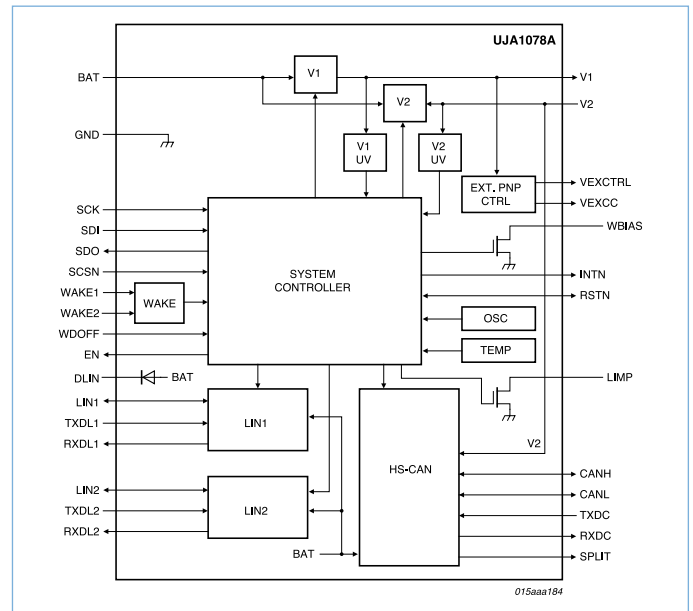

### Active power distribution increases the ECU's thermal performance

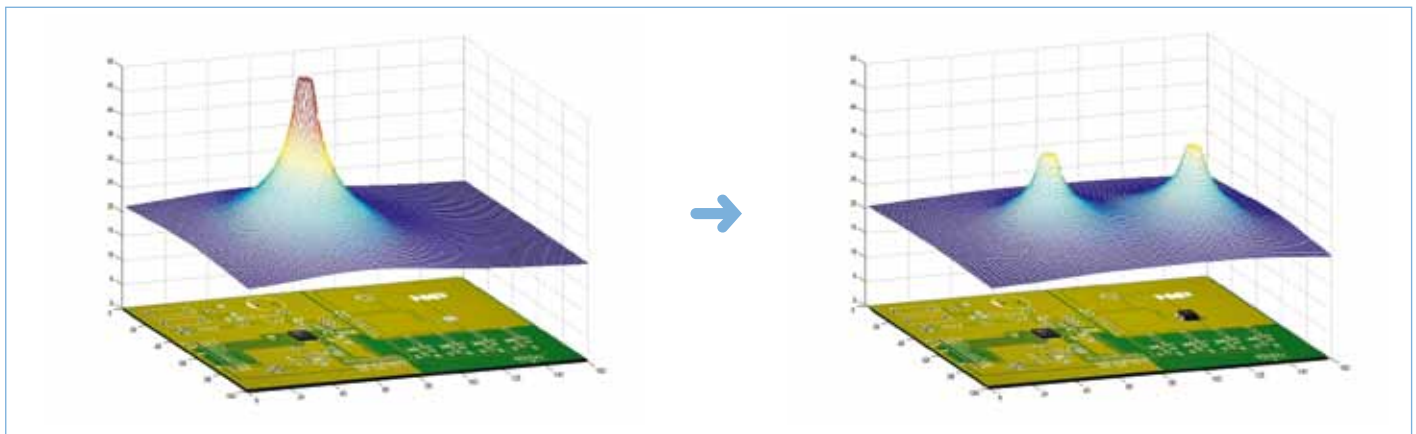

### UJA107xA family

Product no.	Description	MCU supply	Watchdog	Package
UJA1078A	HS-CAN and dual LIN/J2602 SBC	3.3 or 5 V	Optional	HTSSOP32
UJA1075A	HS-CAN and LIN/J2602 SBC	3.3 or 5 V	Optional	HTSSOP32
UJA1076A	HS-CAN SBC	3.3 or 5 V	Optional	HTSSOP32
UJA1079A	LIN/J2602 SBC	3.3 or 5 V	Optional	HTSSOP32

[www.nxp.com](http://www.nxp.com)

© 2010 NXP B.V.

All rights reserved. Reproduction in whole or in part is prohibited without the prior written consent of the copyright owner. The information presented in this document does not form part of any quotation or contract, is believed to be accurate and reliable and may be changed without notice. No liability will be accepted by the publisher for any consequence of its use. Publication thereof does not convey nor imply any license under patent- or other industrial or intellectual property rights.

Date of release: June 2010

Document order number: 9397 750 16964

Printed in the Netherlands