

Video Phone Reference Design

www.streaming-networks.com

OEM-ready system for digital Audio & Video communication



OVERVIEW

The Streaming Networks video phone reference design with Short Message Service (SMS) capability is a complete, OEM-ready system that requires no adjustments or software installations.

HARDWARE COMPONENTS

The reference design includes a processor board and an I/O board. The processor board has a Philips PNX1300 Nexperia media processor (with TriMedia VLIW processor core), SDRAM, and Flash memory. The I/O board has Silicon Laboratory's Analog Front End (AFE), audio and video interfaces, and a power supply. An analog phone module is connected to the I/O board via the AFE. For composing text messages, the phone module's keypad is also fed to the I/O board. The design also includes an integrated, high-quality LCD screen and a wide-angle digital camera.

INTERFACES SUPPORTED

An external A/V input jack supports connection to alternative A/V sources, such as a camcorder, a CVBS/S-Video camera, or audio devices. An A/V output jack makes it possible to record or display the received video from the remote video phone on a standard PAL/NTSC monitor or TV set.

STANDARDS COMPLIANCE

For wide interoperability and reliable performance, the video phone is based on ITU-H.324 standards. These standards establish video communication, with near toll-quality audio, on a regular telephone line. The video phone's H.324 stack does all the video and audio compression and decompression, video multiplexing and demultiplexing, audio and data channel, system control functions and modem functions.

The stack includes an ITU H.263 video codec, an ITU G.723.1 audio codec, an ITU H.223 multiplexer and demultiplexer, an ITU H.245 control protocol, and a 33.6-kbps ITU V.34 soft modem. The video codec supports up to 10 fps CIF and up to 15 fps QCIF, as well as PB, UMV, AC, and SAP options. The audio codec supports 5.3/6.3 kbps plus silence suppression and comfort noise generation.

PRE & POST-FILTERS FOR AUDIO / VIDEO

The video phone also has an enhancement module that goes beyond the H.324 standard to deliver superior video and audio quality. There is an overlay for OSD as well as pre- and post-processing filters for improved video performance. The module also has an audio Acoustic Echo Canceller (AEC) that supports the echo-free, hands-free operation typically found only in high-end video conferencing systems.

MODULAR DESIGN FOR ADDED CUSTOMIZATION

The video phone uses a modular software architecture for increased flexibility and added design longevity. The modular architecture makes it possible to add features, replace the standard library modules with customer-specific modules, or update the standard library to meet new standards.

To help speed time-to-market, Streaming Networks is also available to customize designs.

Single module

Ready to use. No Accessories needed.

Smart Phone Functionality

Address book, call register and graphical OSD

Acoustic Echo Canceller

AEC enables hands echo free and free operation

KEY FEATURES

- Fully functioning video phone with advanced audio/video performance
 - Philips PNX1300 Nexperia media processor (with TriMedia VLIW processor core)
 - SDRAM and Flash memory
 - LCD screen and wide-angle digital camera
 - Silicon Laboratory's Analog Front End (AFE) and analog phone module
 - Audio and video interfaces
 - Power supply
- External A/V input and output jacks
 - Use alternative A/V sources (camcorder, CVBS/S-video camera, audio devices)
 - Record or display received video on PAL/NTSC monitor or TV
- Cost-effective H.324 stack implementation
 - Wide interoperability
 - Reliable performance
- Enhancement module for superior audio/video performance
 - Overlay for OSD
 - Pre- and post-processing filters for video quality
 - Acoustic Echo Cancellation (AEC) for hands-free speakerphone
- Modular software architecture



BLOCK DIAGRAM

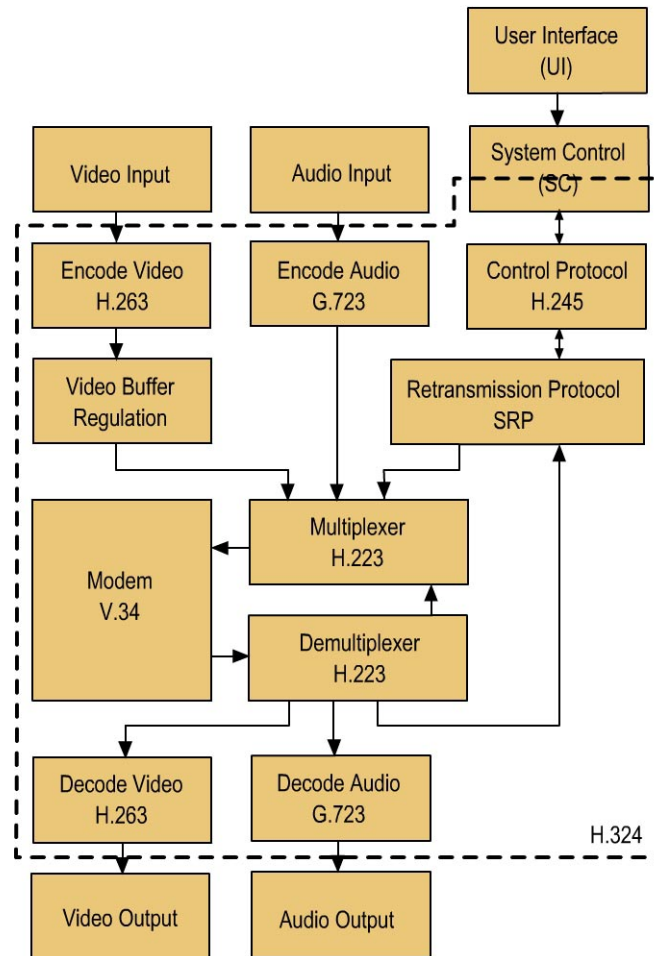

Contact Streaming Networks for more information:

Telephone: +1 (408) 727-3904

Email: info@streaming-networks.com

Web: www.streaming-networks.com

Enabling the Digital Media Revolution